



A Gorman-Rupp Company

SUBMERSIBLE DRAINAGE/ SUMP UTILITY PUMP

- **Stainless Steel, Cast Iron and Plastic Construction**
- **Built-in Thermal Protection**
- **Triples Seal System; Double Mechanical Seals Plus Shaft Seal**
- **Automatic Float Switch Included (Except SS Model No. 5780-98)**
- **115 VAC UL/SJT Cord w/3 Prong Plug**
- **U.L./CSA Listed**
- **1/8 to 1/2 HP**
- **1" to 2" NPT Port Sizes**
- **Max Temperature 104° F**
- **Clog Resistant Impellers**



AMT Submersible Sump Pumps are designed for many applications including sump pits, drainage pits, overflow tanks, basements, dewatering, excavation, grain elevators, construction drainage, cooling towers and other applications requiring clear water removal. AMT submersible pumps (except SS model 5780-98) include automatic float switch, thermal overload protector and suction screen.

AMT Submersible Utility Pumps are reliable, cost effective, low maintenance and many are readily available "Off-the-shelf" for fast 24 hour shipment. For use with non-flammable liquids compatible with pump component materials.

INDUSTRIAL DUTY



Model 5792-95

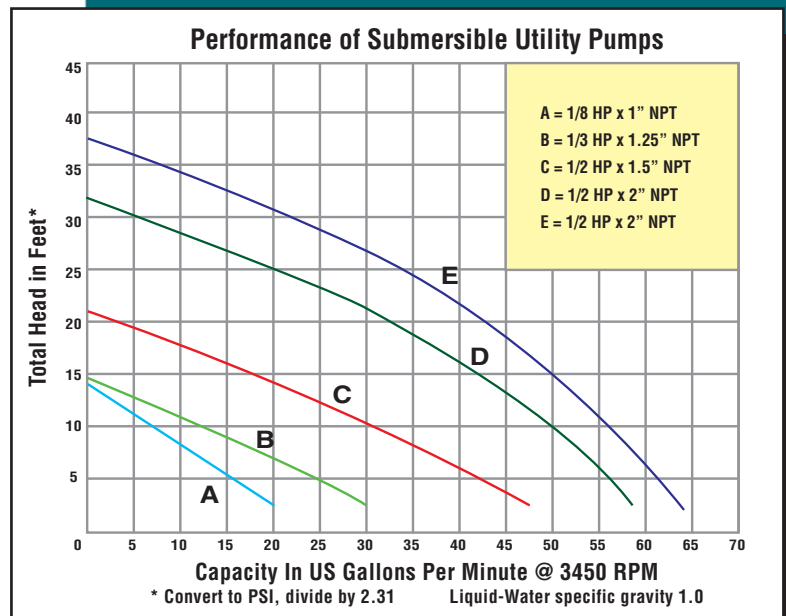

SUBMERSIBLE DRAINAGE/SUMP UTILITY PUMPS

MODEL	CURVE	HP	PORT NPT*	CONSTRUCTION MATERIALS	TYPE	SHIP WT.	VAC @ 60 HZ	AMPS	CORD LENGTH
5800-99	A	1/8	*1.0"	Plastic	Utility	11 lbs.	115	1.5	12 ft.
5810-99	B	1/3	*1.25"	Plastic	Vortex	13 lbs.	115	3.0	12 ft.
5811-99	C	1/2	*1.5"	Plastic	Vortex	15 lbs.	115	4.9	12 ft.
5780-98	E	1/2	2"	Stainless Steel	Drainage	26 lbs.	115	5.0	20 ft.
5792-95	F	1/2	2"	Cast Iron	Drainage	42 lbs.	115	6.9	20 ft.

*SUPPLIED WITH HOSE CONNECTION.

NOTE: Electric supply for ALL motors must be with ± 10% of nameplate voltage.

PUMP DIMENSIONAL AND SPECIFICATION DATA

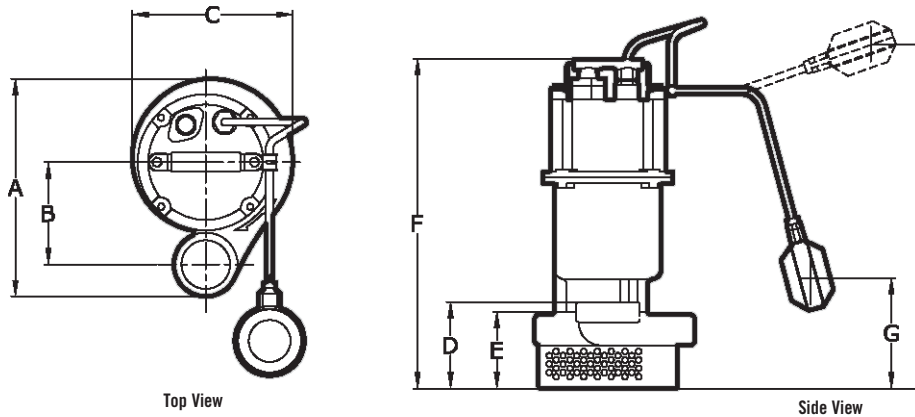

MODEL	SCREEN	A	B	C	D	E*	F	G	H
5800-99	1/8" x 1/8"	N/A	1.3	5.7	9.2	2.0	9.7	3.0	13
5810-99	1/2" x 1-1/2"	9.2	5.4	6.3	4.6	3.2	11.6	3.0	13
5811-99	1/2" x 1-1/2"	9.4	5.5	6.3	4.6	4.2	12.6	3.0	13
5780-98	3/16" Dia.	8.19	4.0	5.63	4.0	3.15	15.0	N/A	N/A
5792-95	1/4" Dia.	10.0	4.8	7.5	3.9	3.4	15.3	3.6	17.8



(*) MINIMUM LIQUID HEIGHT.

NOTE: Dimensions are in inches and have a tolerance of ± 1/8"

Standard Features:

- UL/CSA Listed
- Automatic Float Switch (except SS model 5780-98)
- Double Mechanical Seal Construction
- 580 Series; Plastic Submersibles Include Hose Adapters
- 104° F Max Temperature
- Suction Screen
- 115 VAC UL/SJTW Cord w/3 Prong Plug
- Carry Handle Built In
- Thermal Protection (except SS model 5780-98)

DJ Gongol & Associates, Inc.
 4801 Pommel Place
 West Des Moines, IA 50265
 515-223-4144
 www.gongol.net
 sales@gongol.net



See price book page 40

The Gorman-Rupp Company reserves the right to discontinue any model or change specifications at any time without incurring any obligation.

CP97-98/0904