

PORTABLE HYDRAULIC POWER UNIT

MODEL HT6D

This portable diesel power pack is ideal for driving our 2" pumps and slim-line borehole pump. It also can provide hydraulic power to run many other hydraulic tools . Two models are available with flows of 3 GPM @ 2500 PSI or 4.5 GPM @ 1800 PSI.



Unit Shown with Optional Wheel Kit

FEATURES

- Efficient Yanmar Diesel Engine
- Gear Type Hydraulic Pump
- Roll Cage Frame
- Single Point Lifting Bracket
- Optional Wheel Kit
- Efficient Oil Cooler
- System Relief Valve
- Pressure Control Valve
- Fluid Level Gauge
- Liquid Filled Pressure Gauge
- Spin-On 10 Micron Return Filter
- HTMA Hydraulic Couplers
- Optional Electric Start
- For Flows and Pressures Other Than Standard, Consult Factory

A0899

Model HT6D Overall Dimensions

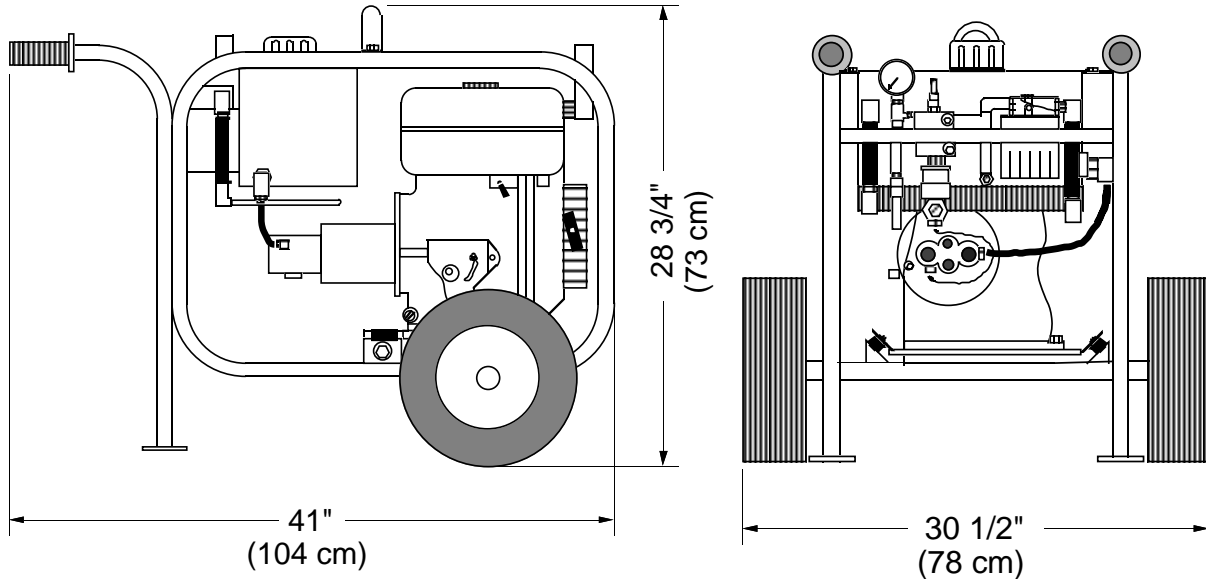

Dimensions shown with optional wheel kit

SPECIFICATIONS

ENGINE:.....Yanmar L60A Diesel
 HORSE POWER:.....6 @ 3500 RPM
 HYDRAULIC OUTPUT:..... 3 GPM (11 LPM) @ 2500 PSI (170 Bar)
 or:.....4.5 GPM (17 LPM) @ 1800 PSI (122 Bar)
 HOSE PORT SIZE:.....1/2" NPT
 HYDRAULIC OIL:.....SAE 10W or 20W Type AW
 also:..Dexron ATF or Bio-degradeable Oil (Consult Factory)
 OIL FILTRATION:.....10 Micron (Standard)
 OIL RESERVOIR CAPACITY:.....4 U.S. Gallons (15.1 Liters)
 FUEL TANK CAPACITY:......92 U.S. Gallons (3.5 Liters)
 FUEL CONSUMPTION:.....Approx. .3 U.S. Gal/Hr (1.1 Liters/Hr)
 DIMENSIONS:.....H 25" (63.5 cm) x W 20" (51 cm) x L 30" (76 cm)
 W/ Wheel Kit H 28 3/4" (73 cm) x W 30 1/2" (78 cm) x L 41" (104 cm)
 WEIGHT (Dry):.....192lbs. (87 kg)

Since we are constantly working to improve our products, specifications are subject to change without notice.