

PORTABLE HYDRAULIC POWER UNIT

MODEL HT13GXR

This power unit features an extended run fuel tank, extra oil cooling and easy handling. Great for continuous duty applications powering our pumps or other hydraulic equipment.



FEATURES

- Reliable Honda Gas Engine
- Roll Cage Frame
- Large Fuel Tank
- Single Point Lifting Bracket
- Gear Type Hydraulic Pump
- Efficient Oil Cooler
- System Relief Valve
- Pressure Control Valve
- Fluid Level Gauge
- Liquid Filled Pressure Gauge
- Spin-On 10 Micron Return Filter
- Low Engine Oil Safety Shutdown
- Optional Electric Start
- For Flows and Pressures Other Than Standard, Consult Factory

A0899

Model HT13GXR Overall Dimensions

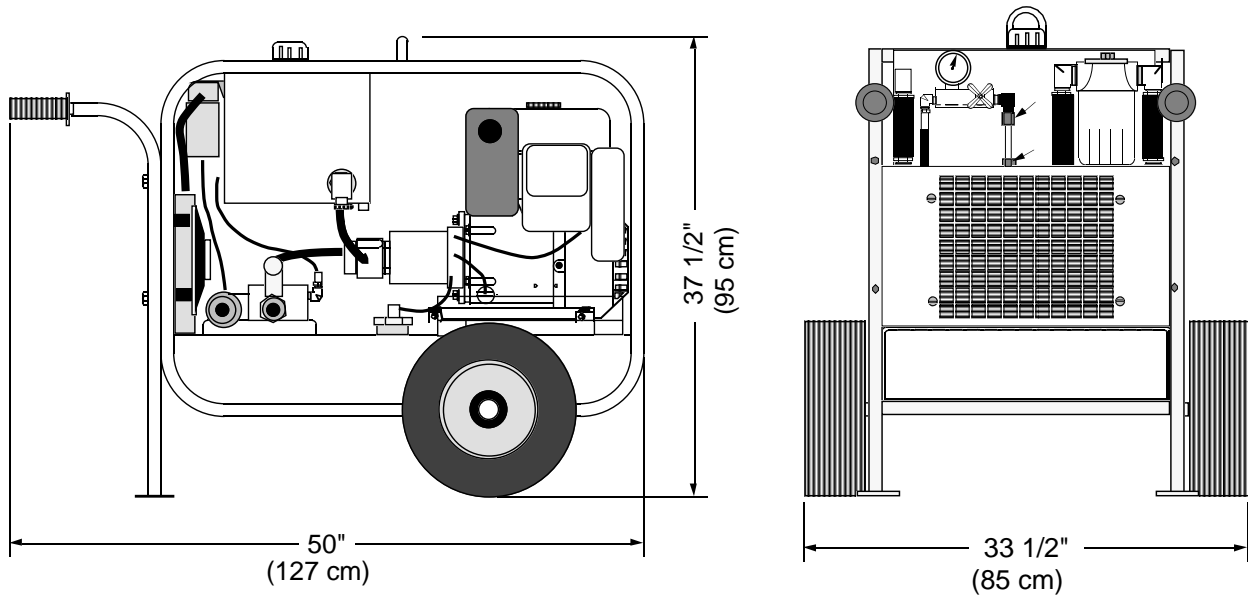

SPECIFICATIONS

ENGINE:.....Honda GX390 Gasoline
 HORSEPOWER:.....13 @ 3500 RPM
 HYDRAULIC OUTPUT:.....Variable Max 6 GPM (23 LPM)
 OPERATING PRESSURE:.....Maximum 2100 PSI (143 Bar)
 HOSE PORT SIZE:.....1/2" or 3/4" NPT
 HYDRAULIC OIL:.....SAE 10W or 20W Type AW
 also: Dexron ATF or Bio-degradeable Oil (Consult Factory)
 OIL FILTRATION:.....10 Micron (Standard)
 OIL RESERVOIR CAPACITY:.....8 U.S. Gallons (30 Liters)
 FUEL TANK CAPACITY:.....15 U.S. Gallons (57 Liters)
 FUEL CONSUMPTION:.....Approx. .9 U.S. Gal/Hr (3.4 Liters/Hr)
 DIMENSIONS:....H 37 1/2" (95 cm) x W 33 1/2" (85 cm) x L 50" (127 cm)
 WEIGHT (Dry):.....355lbs. (161 kg)

Since we are constantly striving to improve our products, specifications are subject to change without notice.