

## **PORTABLE HYDRAULIC POWER UNIT**

### **MODEL HT11DXR**

This diesel power unit features an extended run fuel tank, extra oil cooling and easy handling. Great for continuous duty applications powering our pumps or other hydraulic equipment.



## **FEATURES**

- Efficient Yanmar Diesel Engine
- Electric Start
- Variable Speed
- Single Point Lifting Bracket
- Roll Cage Frame
- Large Fuel Tank
- Gear Type Hydraulic Pump
- Pressure Control Valve
- System Relief Valve
- Liquid Filled Pressure Gauge
- Spin-On 10 Micron Return Filter
- Efficient Oil Cooler
- Fluid Level Gauge
- For Flows and Pressures Other Than Standard, Consult Factory

A0899

## Model HT11DXR Overall Dimensions

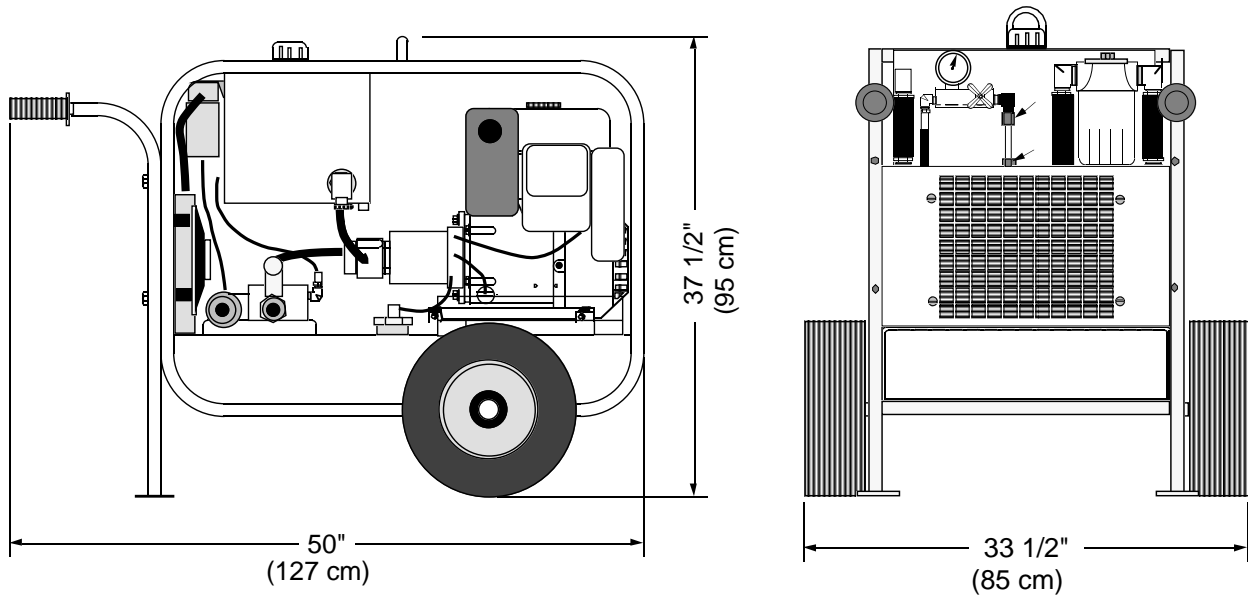

## SPECIFICATIONS

ENGINE:.....Yanmar L100A Diesel  
HORSE POWER:.....11 @ 3500 RPM  
HYDRAULIC OUTPUT:.....Variable, Max 6 GPM (23 LPM)  
OPERATING PRESSURE:.....Maximum 2100 PSI (143 Bar)  
HOSE PORT SIZE:.....1/2" or 3/4" NPT  
HYDRAULIC OIL:.....SAE 10W or 20W Type AW  
also:.. Dexron ATF or Bio-degradeable oil (Consult Factory)  
OIL FILTRATION:.....10 Micron (Standard)  
OIL RESERVOIR CAPACITY:.....8 U.S. Gallons (30 Liters)  
FUEL TANK CAPACITY:.....15 U.S. Gallons (57 Liters)  
FUEL CONSUMPTION:.....Approx. .5 U.S. Gal/Hr (1.9 Liters/Hr)  
DIMENSIONS:....H 37 1/2" (95 cm) x W 33 1/2" (85 cm) x L 50" (127 cm)  
WEIGHT (Dry):.....395lbs. (179 kg)

Since we are constantly striving to improve our products, specifications are subject to change without notice.



P.O. Box 537, Mt. Holly, NJ 08060, USA  
Website: [www.hydra-tech.com](http://www.hydra-tech.com)

Phone: 609-267-5393 FAX: 609-261-8070  
E-Mail: [htpump@hydra-tech.com](mailto:htpump@hydra-tech.com)