

ENGINE-DRIVEN, SOLIDS-HANDLING TRASH PUMPS

Gorman-Rupp 3" engine-driven trash pumps are designed for applications that require high flow efficiency and solids-handling capability. Pumps are constructed of heavy-duty cast aluminum or cast iron with replaceable ductile iron impellers and steel or cast iron wearplates. Front cleanout design, on most models, permits easy removal of trash and debris without disconnecting hoses. Pumps are available with Honda gasoline or Hatz, Kohler or Yanmar diesel engines. All models include a suction strainer and 90° discharge elbow.



Model: 13A52-GX390



Model: 13G1-GX160



Model: 13D-GX270



Model:
13E2-12LD477 S/G

FEATURES

- Cast aluminum or cast iron construction
- Viton® silicon/carbide mechanical or Gorman-Rupp double-lubricated grease seals
- 3" NPT port sizes
- Engine options: Honda gasoline engine; Yanmar, Kohler or Hatz diesel engine
- Heavy-duty steel roll cage or skid base
- Solids-handling to 2" (50 mm) diameter
- Suction strainer and 90° discharge elbow
- Self-priming up to 25 ft. (7,6 m) lift with built-in flap valve
- Replaceable ductile iron impeller and steel wearplate
- Maximum temperature to 160° F (71° C) (to 110° F [43° C] for grease seal)
- Maximum operating pressure to 94 psi (6,4 bar)
- Wheel kit available upon request

GENERAL INFORMATION

| Model | Ship Wt. (Approx.) | Driver Type (HP) | Max. Solids | Suc. x Dis. (NPT) | Basic Construction | Seal Type & Elastomer/Faces | Tank Size | Run Time | Mounting |
|-------------------|--------------------|----------------------|-----------------|-------------------|--------------------|-----------------------------|-----------|-----------|-----------|
| 13A52-GX390 | 387 lbs. | Honda Gasoline | 1-1/2" (38 mm) | 3" x 3" | Cast Iron | Viton®* Silicon/Carbide | 1.7 gal. | 2.6 hrs. | Roll Cage |
| 13D1-GX270 | 136 lbs. | Honda Gasoline | 1-1/2" (38 mm) | 3" x 3" | Aluminum | Viton®* Silicon/Carbide | 1.6 gal. | 2.7 hrs. | Roll Cage |
| 13D-GX270 | 136 lbs. | Honda Gasoline | 1-1/2" (38 mm) | 3" x 3" | Aluminum | Gorman-Rupp Grease | 1.6 gal. | 2.7 hrs. | Roll Cage |
| 13D1-L70EE | 124 lbs. | Yanmar Diesel (6.7) | 1-1/2" (38 mm) | 3" x 3" | Aluminum | Viton®* Silicon/Carbide | 0.92 gal. | 2.2 hrs. | Roll Cage |
| 13D-L70EE | 124 lbs. | Yanmar Diesel (6.7) | 1-1/2" (38 mm) | 3" x 3" | Aluminum | Gorman-Rupp Grease | 0.92 gal. | 2.2 hrs. | Roll Cage |
| 13D1-L70EE S/G* | 144 lbs. | Yanmar Diesel (6.7) | 1-1/2" (38 mm) | 3" x 3" | Aluminum | Viton®* Silicon/Carbide | 1.45 gal. | 3.4 hrs. | Roll Cage |
| 13D-L70EE S/G* | 144 lbs. | Yanmar Diesel (6.7) | 1-1/2" (38 mm) | 3" x 3" | Aluminum | Gorman-Rupp Grease | 1.45 gal. | 3.4 hrs. | Roll Cage |
| 13E2-12LD477 S/G* | 655 lbs. | Kohler Diesel (15.5) | 2" (50 mm) | 3" x 3" | Cast Iron | Gorman-Rupp Grease | 11.0 gal. | 18.9 hrs. | Skid Base |
| 13E52-GX390 | 363 lbs. | Honda Gasoline | 2" (50 mm) | 3" x 3" | Cast Iron | Viton®* Silicon/Carbide | 1.7 gal. | 1.9 hrs. | Roll Cage |
| 13G1-GX160† | 100 lbs. | Honda Gasoline | 1-3/16" (30 mm) | 3" x 3"† | Aluminum | Viton®* Silicon/Carbide | 0.95 gal. | 2.0 hrs. | Roll Cage |
| 13G1-1B20† | 121 lbs. | Hatz Diesel (4.7) | 1-3/16" (30 mm) | 3" x 3"† | Aluminum | Viton®* Silicon/Carbide | 0.79 gal. | 2.6 hrs. | Roll Cage |

*12 volt electric start. Battery not included. †BSP flange kits available. *Viton® is a registered trademark of DuPont.

ENGINE-DRIVEN, SOLIDS-HANDLING TRASH PUMPS

10 SERIES

PERFORMANCE CURVES

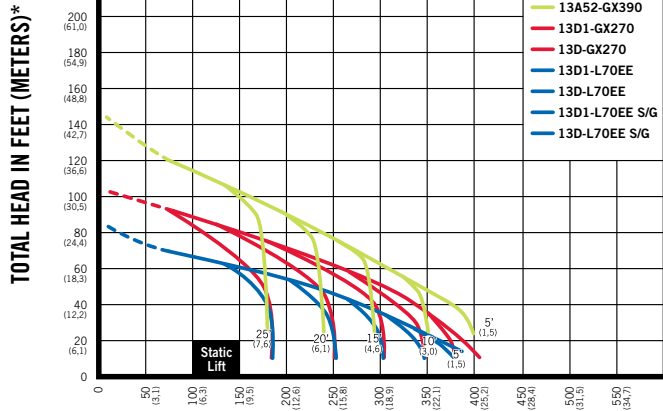

U.S. GALLONS PER MINUTE (LITERS PER SECOND)

Curves are based on a specific gravity of 1.0 *To convert to PSI divide by 2.31

PERFORMANCE CURVES

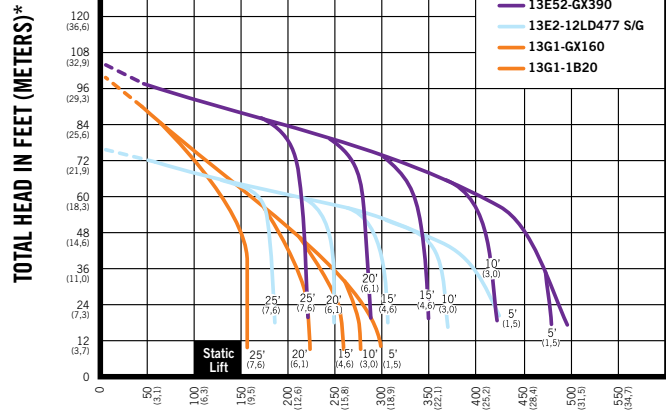

U.S. GALLONS PER MINUTE (LITERS PER SECOND)

Curves are based on a specific gravity of 1.0 *To convert to PSI divide by 2.31

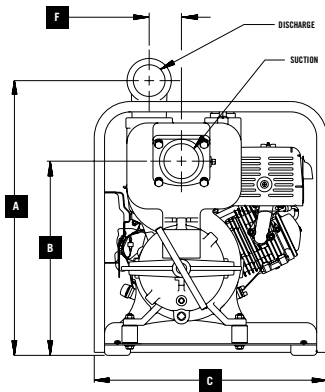

MODEL: 13A52-GX390

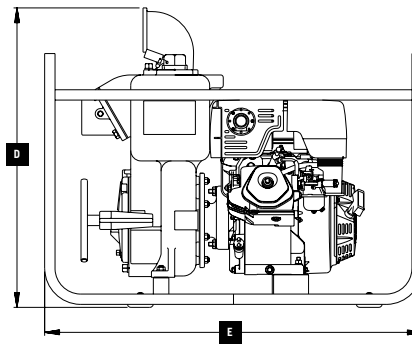

PUMP DIMENSIONAL DATA

| Model | A | B | C | D | E | F | Suction* | Discharge* |
|------------------|-------------------|-------------------|-------------------|-------------------|--------------------|-------------------|----------|------------|
| 13A52-GX390 | 26.56 (674,60) | 18.78 (477,00) | 22.50 (571,50) | 28.95 (735,30) | 36.50 (927,10) | 3.12 (79,20) | 3.00 | 3.00 |
| 13D1-GX270 | 21.50 (546,20) | 13.62 (345,90) | 20.00 (480,10) | 23.62 (599,90) | 28.00 (711,20) | 00.00 (000,00) | 3.00 | 3.00 |
| 13D-GX270 | 21.50 (546,20) | 13.62 (345,90) | 20.00 (480,10) | 23.62 (599,90) | 28.00 (711,20) | 00.00 (000,00) | 3.00 | 3.00 |
| 13D1-L70EE | 22.28 (565,90) | 14.44 (366,80) | 21.00 (533,40) | 24.41 (620,00) | 28.00 (711,20) | 00.00 (000,00) | 3.00 | 3.00 |
| 13D-L70EE | 22.28 (565,90) | 14.44 (366,80) | 21.00 (533,40) | 24.41 (620,00) | 28.00 (711,20) | 00.00 (000,00) | 3.00 | 3.00 |
| 13D1-L70EE S/G | 22.28 (565,90) | 14.44 (366,80) | 21.00 (533,40) | 24.41 (620,00) | 28.00 (711,20) | 00.00 (000,00) | 3.00 | 3.00 |
| 13D-L70EE S/G | 22.28 (565,90) | 14.44 (366,80) | 21.00 (533,40) | 24.41 (620,00) | 28.00 (711,20) | 00.00 (000,00) | 3.00 | 3.00 |
| 13E2-12LD477 S/G | 28.93 (734,80) | 20.30 (515,62) | 30.26 (768,60) | 31.07 (789,20) | 43.00 (1092,20) | 00.00 (000,00) | 3.00 | 3.00 |
| 13E52-GX390 | 25.86 (656,84) | 17.44 (442,98) | 22.50 (571,50) | 28.00 (711,20) | 36.50 (927,10) | 00.00 (000,00) | 3.00 | 3.00 |
| 13G1-GX160 | 15.10 (383,54) | 7.40 (187,96) | 18.00 (457,00) | 18.75 (476,00) | 24.00 (610,00) | 00.00 (000,00) | 3.00 | 3.00 |
| 13G1-1B20 | 15.60 (396,24) | 7.90 (200,66) | 18.00 (457,00) | 18.75 (476,00) | 24.00 (610,00) | 00.00 (000,00) | 3.00 | 3.00 |



To order, visit <http://www.pumpstoreusa.com/store/trashpumps/> or call 515-223-4144

*Standard NPT Pipe Threads

©2011-2013 The Gorman-Rupp Company. The Gorman-Rupp Company reserves the right to discontinue any model or change specifications at any time without incurring any obligation.

O05-0010