



# 2" Engine Driven Dredging Pump

- **High Chromium Stainless Steel Internal Components Resist Wear from Sea Water Mixed with Abrasive Sand**
- **Silicon Carbide Mechanical Seal Resists Abrasives and Extends Seal Life**
- **Heavy Duty Cast Iron Casing and Adapter Ensures Durability for Severe Service Conditions**
- **Dual Volute Design**
- **O-Ring Casing Seal for Ease of Service and Cleaning**
- **Maximum Working Pressure 75 PSI**
- **Maximum Temperature 160° F**
- **Maximum Flow 173 GPM**
- **Discharge Pressure up to 44 PSI**
- **Handles up to 1/2" Diameter Solids**
- **Self-primes to 10 ft. in 1 Minute!!**
- **Maximum Suction Lift 20 ft.**
- **Available with Honda Gasoline and Yanmar Diesel Engines**

AMT Engine Driven Dredging pump is designed for pumping sea water and fresh water containing up to 25% sand, debris and other abrasive particles. This unit can be used for other marine applications including dredging, pile driving, pier maintenance, emergency bilging and wash down.

This pump is constructed of wear resistant High Chromium Stainless Steel internal components that are designed to last for over 500 hours of service with regular maintenance of rinsing pump after each use. The High Chromium Stainless Steel components are investment cast and CNC machined for maximum efficiency, performance and quality. Dual volute design reduces radial load on engine. The 4-bolt casing design and removable type volute offer simple maintenance and fast cleanout of the pump.

AMT Dredging pumps are reliable, cost effective and low maintenance. For use with non-flammable liquids compatible with pump component materials.



**316F-95 Dredging Pump**

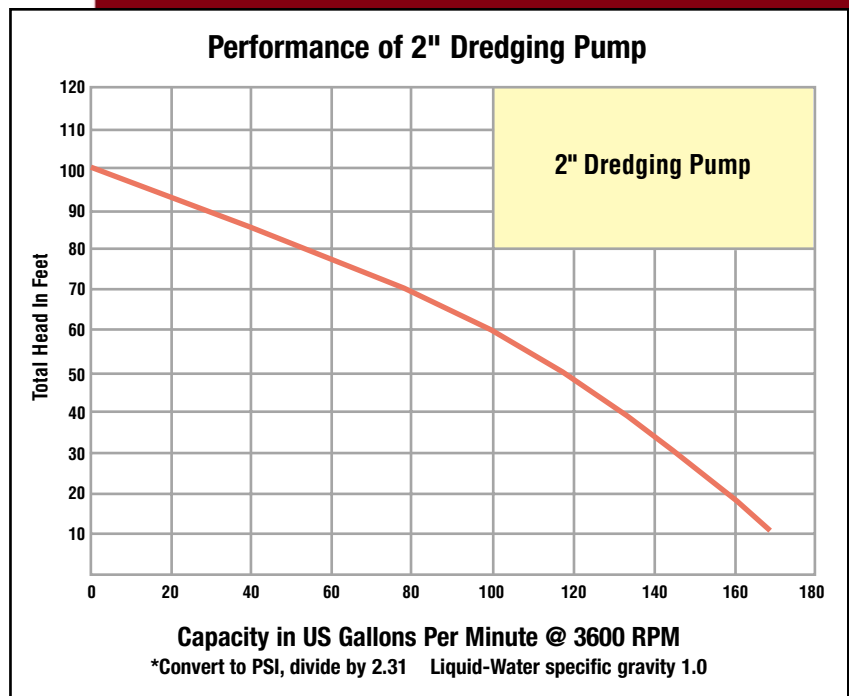

# 2" Engine Driven Dredging Pump

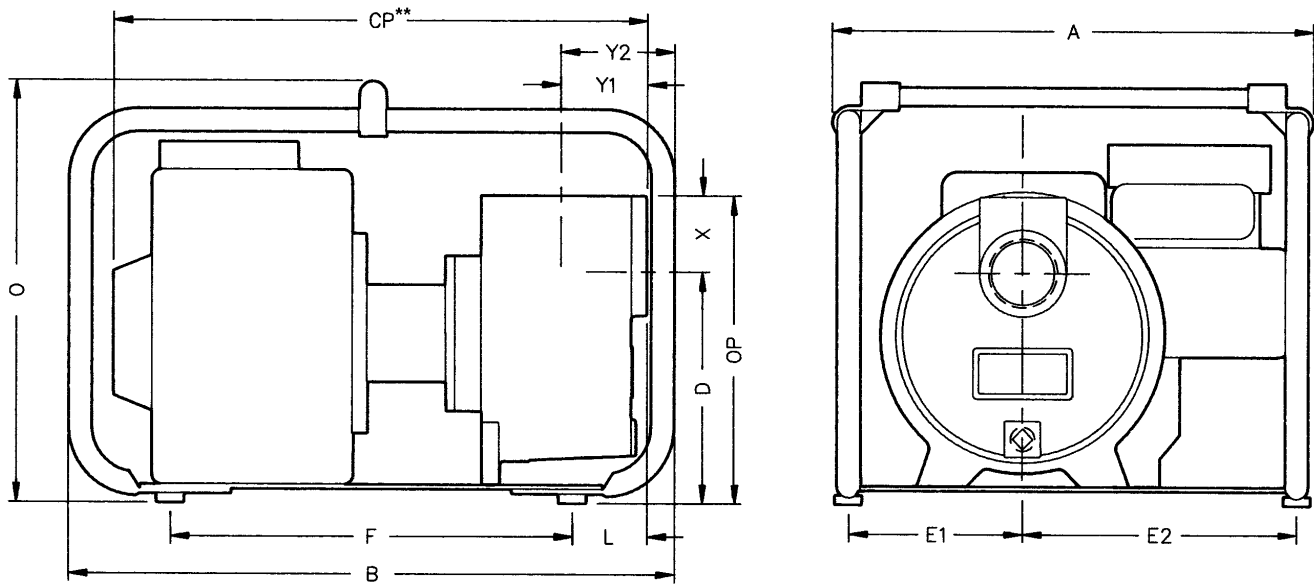

**Pump Dimensional Data**

Model No.	A	B	CP**	D	E1	E2	F	L	O	OP	X	Y1	Y2
316F-95	19.5	24.3	19.0	6.8	7.0	11.0	9.3	6.0	20	9.5	2.6	3.1	4.6
316F-D5	19.5	24.3	19.0	6.8	7.0	11.0	9.3	6.0	20	9.5	2.6	3.1	4.6
316F-99*	8.0	N/A	15.1	6.3	1.9	1.9	2.5	4.9	8.9	8.9	2.6	3.1	N/A

(\*\*) This dimension may vary due to engine manufacturer's specifications. (\*) Minimum 5hp required.

**NOTE:** Dimensions have a tolerance of  $\pm 1/8"$ .

Model No.	Port Size	Driver	Construction	Seal	Run Time	Tank Size	Max Solids	Ship Wt.
316F-95	2" NPT	Honda GX160 OHV with Oil Alert	Cast Iron w/ High Chromium Stainless Steel Wear Parts	Silicon Carbide w/ Buna-N	100 min.	3.8 Qt	1/2"	85 lbs.
316F-D5	2" NPT	Yanmar Diesel L48	Cast Iron w/ High Chromium Stainless Steel Wear Parts	Silicon Carbide w/ Buna-N	110 min.	2.6 Qt	1/2"	95 lbs.
316F-99	2" NPT	Pedestal Ball Bearing w/3/4" Keyed Shaft	Cast Iron w/ High Chromium Stainless Steel Wear Parts	Silicon Carbide w/ Stainless Buna-N	N/A	N/A	1/2"	50 lbs.

## Standard Features

- High Chromium Stainless Steel Internal Components Resist Wear from Sea Water Mixed with Abrasive Sand
- Silicon Carbide/Buna-N Mechanical Seal Resists Abrasives and Extends Seal Life
- Heavy Duty Cast Iron Casing and Adapter Insures Durability for Severe Service Conditions
- O-ring Casing Seal for Ease of Service and Cleaning
- Maximum Working Pressure 75 PSI
- Maximum Temperature 160° F
- Maximum Flow 173 GPM
- Maximum Head 101 ft. @ Sea Water (42 PSI)
- Handles up to 1/2" Diameter Solids
- Self-priming to 10 ft. in 1 Minute; Maximum 20 ft. lift
- Includes (2) NPT Pipe Nipples and Suction Strainer
- Available with Honda Gasoline and Yanmar Diesel Engines



See price book page 1

The Gorman-Rupp Company reserves the right to discontinue any model or change specifications at any time without incurring any obligation.

CP9-10 / 1006