

D-025 COMBINATION AIR VALVE FOR SEWAGE - "SAAR" SHORT VERSION

Guarantees complete separation of the liquid from the sealing mechanism by creating an air gap at the top of the valve.

- The air gap is guaranteed even under extreme conditions, this is achieved by a conical body shape that maintains maximum distance between the liquid and the Sealing Mechanism; with minimum body length.
- Spring loaded joint between the stem and the upper float, to ensure that vibrations of the lower float will not unseal the automatic valve. Release of air will occur only after the accumulation of enough air.
- Funnel-shaped lower body ensures that the residue sewage matter will sink to the system and be carried away.
- Self cleaning mechanism.

Includes A.R.I patent: Rolling Seal Mechanism.

Reliable operation reduces water hammer incidents.

Dynamic design allows high velocity air discharge, exceeding 12 psi differential pressure; preventing premature closing.

Lightweight, small dimensions, simple and reliable structure.

All inner metal parts made of stainless steel SAE 316.

The drainage outlet enables removal of excess fluids.

Body made of Stainless Steel SAE 316 or Reinforced Nylon.

Working pressure range: 0.2 - 10 bar. (3-150 psi)

Available in 2" (50mm) , 3" (80mm) , 4" (100mm) - Threaded or Flanged.

Ordering

Upon ordering, please specify: model, size, working pressure, threads/flanges standard and type of liquid.



A.R.I. Flow Control Accessories

Kfar Charuv, 12932 Israel Tel. 972-6-6761988 Fax. 972-6-6763402

<http://arivalves.com>

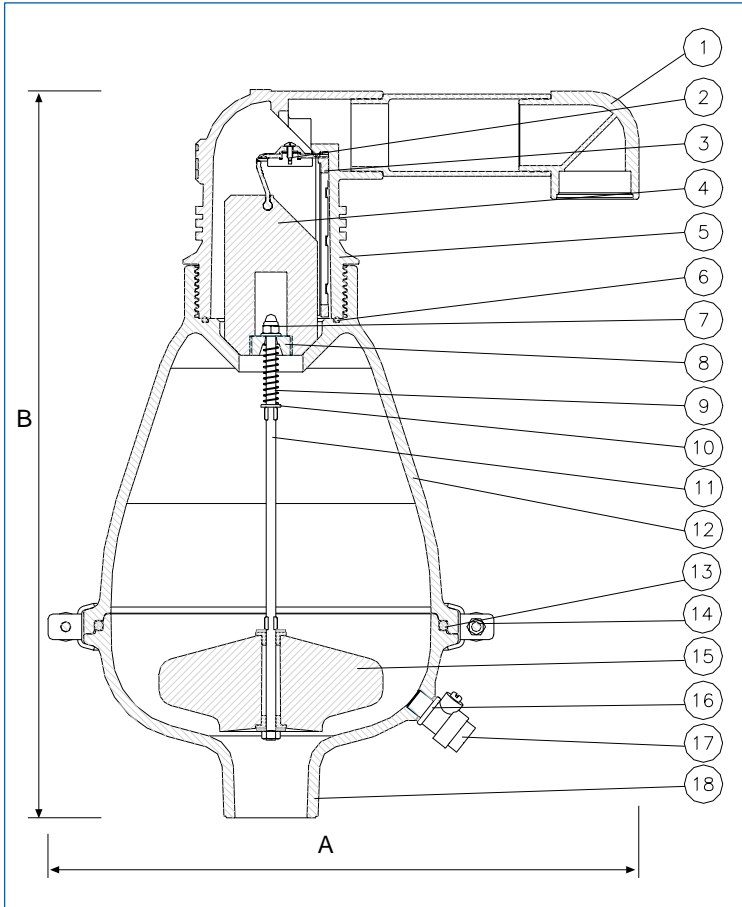

PARTS LIST AND SPECIFICATION

No.	Part	Material
1.	Drainage Elbow	Polypropylene
2.	Seal Plug Assembly	Reinforced Nylon + E.P.D.M. +St.St
3.	Clamping Stem	Reinforced Nylon
4.	Float	Foamed polypropyle
5.	Body	Reinforced Nylon
6.	O-Ring	BUNA-N
7.	Crown nut	Stainless Steel SAE 316
8.	Stopper	Acetal
9.	Spring	Stainless Steel SAE 316
10.	Washer	Stainless Steel SAE 316
11.	Stem	Stainless Steel SAE 316
12.	Body	Reinforced Nylon/Stainless Steel SAE 316
13.	O-Ring	BUNA-N
14.	Clamp	Stainless Steel SAE 316
15.	Float	Foamed polypropyle
16.	Seal	Fiber
17.	Valve	Brass ASTM A124
18.	Base	Reinforced Nylon/Stainless Steel SAE 316

DIMENSIONS AND WEIGHTS

Nominal Size	A	B	Weight Kg.	
			Nylon	St.St.
2" (50mm)	369	455	3.7	14
3" (80mm)	369	455	3.8	15
4" (100mm)	369	455	3.9	16

KINETIC AIR DISCHARGE CHART

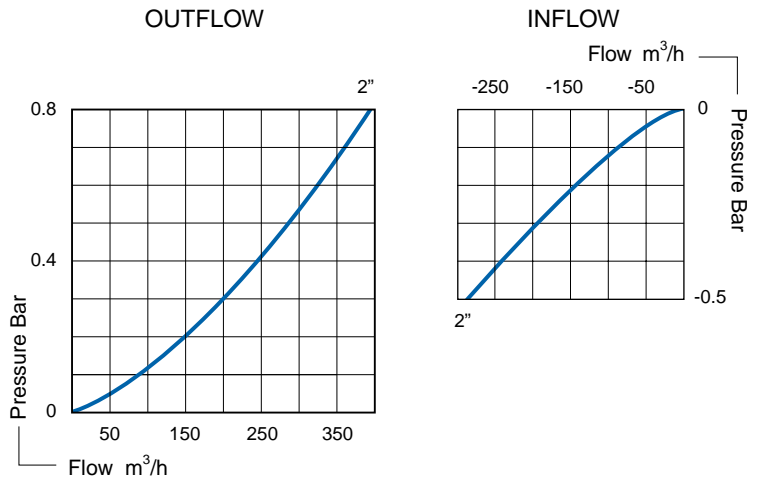

ORIFICE SIZE AREA mm²

Automatic Orifice	12
Kinetic Orifice	804

Threads: BSPT/NPT.
Flanges are available in BS/ISO/ANSI standards.

AUTOMATIC AIR DISCHARGE CHART

