

Gasoline Engine Driven



Self Priming Centrifugal Pump

Models 13D-GX270 and 13D1-GX270

Size 3" x 3"



18 MTC

Click here for prices or to buy now

Total Head		Capacity Of Pump In U.S. Gallons Per Minute (GPM) At Continuous Performance				
P.S.I.	Feet					
35.9	83	87	87	87	87	87
34.7	80	100	140	149	150	150
30.3	70	138	182	205	205	205
26.0	60	165	210	242	255	258
21.7	50	177	227	266	292	302
17.3	40	182	240	282	315	335
13.0	30	184	249	292	328	356
8.7	20	185	252	300	338	370
Suction Lift		25'	20'	15'	10'	5'



PUMP SPECIFICATIONS

- Size:** 3" x 3" (76 mm x 76 mm) NPT - Female.
- Casing:** Aluminum Alloy 356-T6 w/Gray Iron 30 Cutwater Insert.
Maximum Operating Pressure 66 psi (455 kPa).*
- Semi-Open Type, Two Vane Impeller:** Ductile Iron 65-45-12.
Handles 1 1/2" (38,1 mm) Diameter Spherical Solids.
- Replaceable Wear Plate:** Carbon Steel ASTM A36.
- Removable Cover Plate:** Aluminum Alloy 356-T6; 4 lbs. (1.8 kg.).
- Intermediate Bracket:** Aluminum Alloy 356-T6.
- Seal:**
 - (13D)** Double, Grease-Lubricated w/Spring-Loaded Grease Cup. Sintered Bronze Stationary Seal Seats. Steel Rotating Faces. Neoprene Packing Rings. Maximum Temperature of Liquid Pumped, 110°F (43°C). Maximum Suction Pressure 10 psi (69 kPa).*
 - (13D1)** Type 31, Mechanical, Self-Lubricated. Silicon Carbide Rotating and Stationary Faces. Fluorocarbon Elastomers (DuPont Viton® or Equivalent). Stainless Steel 316 Cage and Spring. Maximum Temperature of Liquid Pumped 160°F (71°C).*
- Seal Liner: (13D)** Copper Alloy C26000.
- Shaft Sleeve: (13D1)** Alloy Steel 4130.
- Flap Valve:** Buna-N w/Nylon Reinforcing; Steel and Brass.
- Suction Flange:** Aluminum Alloy 356-T6.
- Gaskets:** Cork w/Nitrile Binder (NC710).
- O-Ring:** Buna-N.
- Hardware:** Standard Plated Steel.
- Roll Cage with Rubber Feet.**
- 90° Discharge Elbow.**
- Strainer.**

Optional Equipment: Wheel Kit w/Semi-Pneumatic Tires.

**Consult Factory for Applications Exceeding Maximum Pressure and/or Temperature Indicated.*

WARNING!

Do not use in explosive atmosphere or for pumping volatile flammable liquids.

ENGINE SPECIFICATIONS:

- Model:** Honda GX270
- Type:** Single Cylinder, Four Cycle, Air Cooled, Overhead Valve, Gasoline Engine.
- Displacement:** 16.5 Cu. In. (270 cc).
- Carburetor:** Horizontal Type.
- Cylinder:** Aluminum Alloy w/Cast Iron Liner.
- Lubrication:** Splash System.
- Air Cleaner:** Dry Type, Dual Element.
- Fuel Tank:** 1.4 U.S. Gallons (5,3 Liters)
- Full Load Operating Time:** Unavailable.**
- Ignition System:** Transistorized Magneto.
- Standard Equipment:** Muffler w/Guard. Manual Throttle Control with Top Speed Limit. Manual Choke. "Oil Alert™" Low Oil Shut Down.

*** Fuel Consumption Data Not Available From Engine Manufacturer.*



GORMAN-RUPP PUMPS

www.grpumps.com

Specifications Subject to Change Without Notice



DJ Gongol & Associates, Inc.

PO Box 180 | West Des Moines, IA 50061-0180
4328 North Dawson | Cumming, IA 50061
515-223-4144 | 515-981-0581 fax
info@gongol.net

Specification Data

APPROXIMATE DIMENSIONS and WEIGHTS

NET WEIGHT: 126 LBS. (57 KG.)
SHIPPING WEIGHT: 136 LBS. (62 KG.)
EXPORT CRATE: 6.3 CU. FT. (0,19 CU. M.)
WHEEL KIT ADD 25 LBS. (11,3 KG.);
SHIPPING CRATE (SEPARATE) 3 CU. FT. (0,1 CU. M.)

SECTION 45, PAGE 555

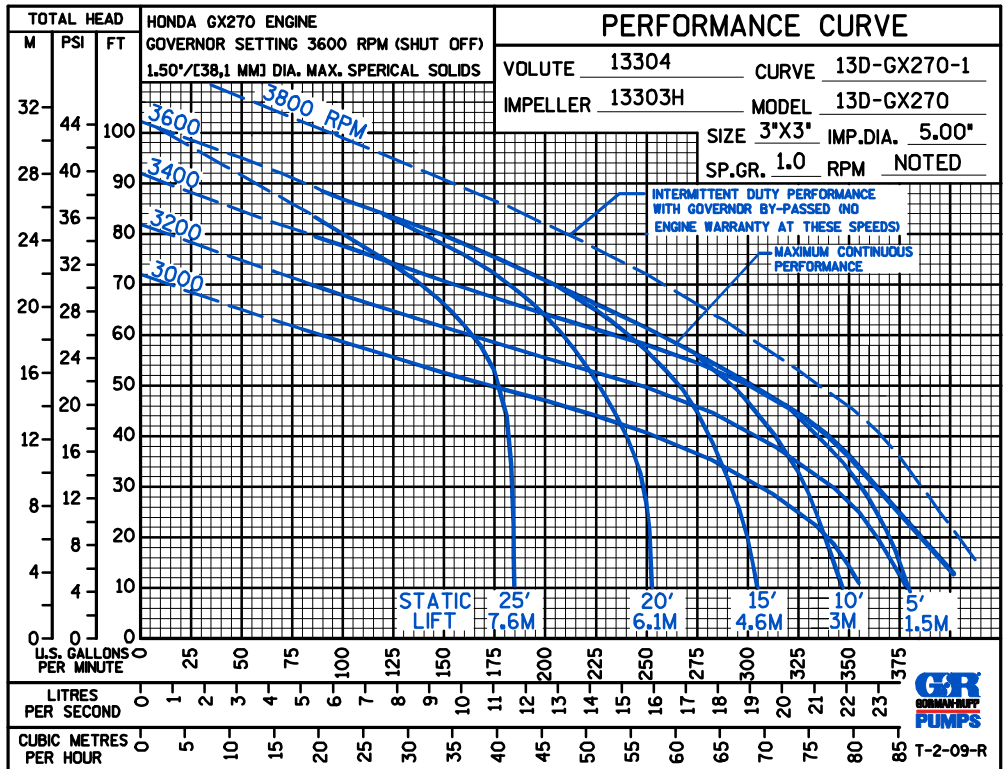
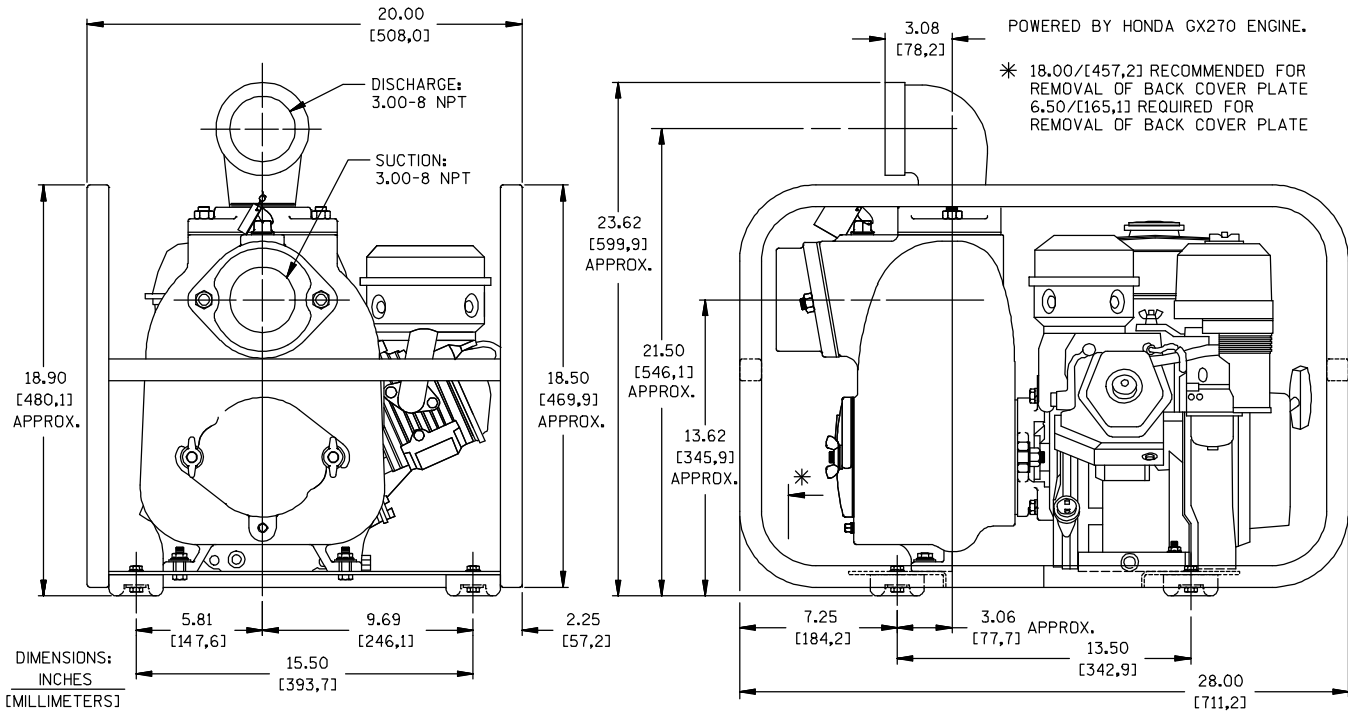

GORMAN-RUPP PUMPS

www.grpumps.com

Specifications Subject to Change Without Notice

© Copyright Gorman-Rupp Pumps 2014



DJ Gongol & Associates, Inc.

PO Box 180 | West Des Moines, IA 50061-0180

4328 North Dawson | Cumming, IA 50061

515-223-4144 | 515-981-0581 fax

info@gongol.net