

Click here
for prices
or to buy now



Model 3168-95
2" Cast Iron
Solids Handling
Pumps



Model 327A-V5
3" Cast Iron Solids Handling Pump

The AMT line of Engine Driven Solids Handling pumps offers an upgraded debris handling capability in wear resistant cast iron construction. Applications include: high volume liquid transfer, irrigation, commercial draining and construction. All models feature durable all cast iron construction and clog-resistant impeller to ensure a long life for the complete pump. Dual volute design reduces radial load on engines.

Gasoline & Diesel Driven Solids Handling Pumps

- **Heavy Duty Cast Iron Construction**
- **Buna-N or Viton® Mechanical Seal Options**
- **2" to 3" NPT Port Sizes**
- **Self-Priming up to 20 Ft.**
- **Semi-Open, Clog Resistant Impeller**
- **Engine Options: Honda, Briggs & Stratton Gasoline or Hatz Diesel**
- **Electric Start Options Available**
- **Heavy Duty Steel Roll Frame Included**
- **Optional Wheel Kit Available**
- **Built-in Check Valve**

Performance of Engine Driven Solids Handling Pumps

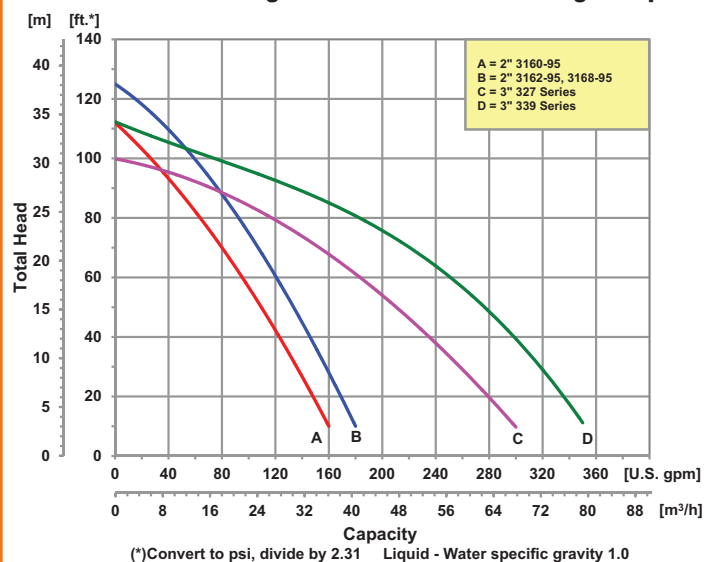

A Gorman-Rupp Company



DJ Gongol & Associates, Inc.

PO Box 180 | West Des Moines, IA 50061-0180
4328 North Dawson | Cumming, IA 50061
515-223-4144 | 515-981-0581 fax
info@gongol.net

For use with nonflammable liquids compatible with pump component materials. Viton® and Teflon® are registered trademarks of E. I. DuPont.

2" Solids Handling Pumps

Model	Curve	Port	Driver	Seals	Run Time (Hours)	Tank Size (Gal/Ltr.)	Ship Wt. (Lbs.)
3160-95	A	2" NPT	Briggs & Stratton	Buna-N	1.2	0.52/2.0	75
3162-95	B	2" NPT	Briggs & Stratton [▲]	Buna-N	1.3	0.87/3.3	82
3168-95	B	2" NPT	Honda GC160	Buna-N	1.5	0.47/1.7	80

Construction: Cast Iron

Maximum Solids Handling Capacity: 3/8" Diameter

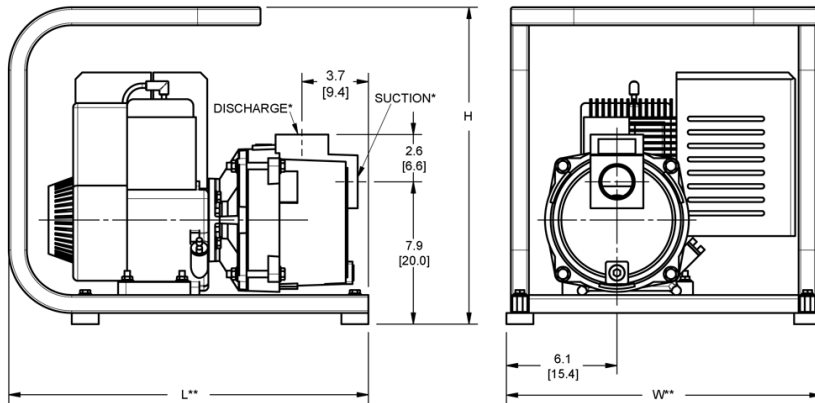

3" Solids Handling Pumps

Model	Curve	Port	Driver	Seals	Run Time (Hours)	Tank Size (Gal/Ltr.)	Ship Wt. (Lbs.)
327A-V5	C	3" NPT	Honda GC160	Viton [®]	1.5	0.47/1.7	110
3391-Z5	D	3" NPT	Hatz Diesel 1B30 ^{++▲}	Viton [®]	2.8	1.32/5.0	215
3390-95	E	3" NPT	B & S Vanguard [▲]	Buna-N	1.3	0.95/3.6	140
3391-V5	E	3" NPT	Honda GX270 ^{++▲}	Viton [®]	2.5	1.40/5.2	170

Construction: Cast Iron

Maximum Solids Handling Capacity: 3/4" Diameter

(♦) HP Class represents market category and is not intended to define actual horsepower

(*) Standard NPT pipe thread

(**) This dimension may vary due to engine manufacturer's specifications.

NOTE: Dimensions are in inches (centimeters) and have a tolerance of ± 1/8".

++ 12V DC Electric Start (Battery Not Included)

▲ Oil Alert Included

Model	HP Class ♦	SUC*	DIS*	L**	W**	H
316 Series	4/5 HP	2" FNPT	2" FNPT	20.0 [50.8]	17.5 [44.4]	17.6 [44.7]
327 Series	5 HP	3" FNPT	3" MNPT	24.0 [60.9]	19.2 [48.7]	18.6 [47.2]
339 Series	8 HP	3" FNPT	3" MNPT	31.0 [78.7]	22.5 [57.1]	23.6 [59.9]

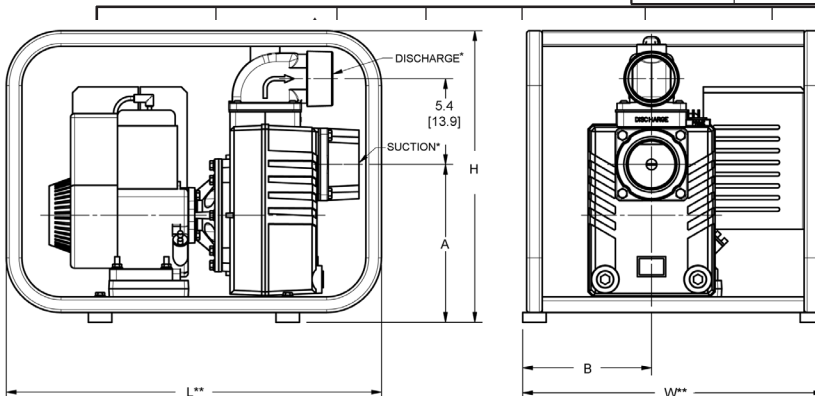

Standard Features

- Viton[®] or Buna-N Mechanical Seals Options
- Self-priming to 20 Ft.
- Semi-open, Clog Resistant Cast Iron Impeller
- Stainless Steel Shaft Sleeve
- Maximum Temperature:
Buna-N 180° F
Viton[®] 200° F
- Maximum Working Pressure 75 PSI
- Wear Resistant Cast Iron Construction and Solids Handling Impeller
- Built-in Check Valve
- Heavy Duty Steel Roll Frame Included
- Pipe Nipple/Discharge Elbow/Strainer
 - 316 Series Includes: (1) Pipe Nipples, (1) Discharge Elbow & (1) Strainer
 - 327/339 Series Includes: (1) Pipe Nipple, (1) MNPT Discharge Elbow & (1) Strainer
- QSP - Quick Ship Pumps for Many Models

Optional Wheel Kit For Roll Frame Pumps

Model	Features	Ship Wt. (Lbs.)
C402-90	Includes 10" semi-pneumatic tires on steel wheels with steel clamps and handles for universal mounting to frame.	25